

AUTOMATIC DESIGNING SYSTEM FOR PIPING AND INSTRUMENTS ARRANGEMENT INCLUDING BRANCHES OF PIPES

H Kimura, Kyushu University, JAPAN

SUMMARY

Automatic design of piping layout is challenging since it is composed of several numerical and/or combinational optimization problems, e.g., routing problems of pipes including branches, and arrangement problems of equipments. This paper presents a new approach that the branches of pipes are considered to be a variety of equipment. Accordingly, the pipe routing problems are fairly simplified by removing the branches, and it derives a lot of efficient algorithms to solve the pipe arrangement problems. One is a multi-objective genetic algorithm (MOGA) in which the gene represents both the locations of the equipments and the arrangement of the pipes. And a new crossover operation which merges two different piping layouts is proposed. To provide a fairly good initial population for the MOGA, a new heuristics making use of self-organization techniques to arrange equipments is proposed. The efficiency of the approach is demonstrated through two experiments, one is a designing problem including five valves, one pump, and five branches, and the other includes seven valves, one pump, and six branches.

1. INTRODUCTION

Recently, pipe routing design process is reinforced by making use of 3D-CAD systems, so that designers can easily verify the arrangement visually. However, automatic designing of piping layout is challenging because it is composed of several numerical and/or combinational optimization problems, e.g., routing problems of pipes including branches, and arrangement problems of equipments.

Chen (1999)[1] and Wang et al. (2006)[2] proposed path planning algorithms based on genetic Algorithms (GA). Park and Storch (2002)[3] proposed a pipe-routing algorithm which divides pipes into several pipeline groups and arranges the pipelines by selecting from finite patterns. Ito (1999)[4] proposed a new pipe routing approach combined with Dijkstra path planning algorithm and GA. Asmara and Nienhuis (2006, 2007)[5][6] developed Delft-Route system which arranges pipes and branches by combining Dijkstra path planning algorithm and an evolutionary algorithm, and it is applied to a practical ship design problem, and AISROUTE presented by Martins and Lobo (2009)[7] is also a similar approach.

This paper presents a new approach that the branches of pipes are considered to be a variety of equipment. Accordingly, the pipe routing problems are fairly simplified by removing the branches, and it derives a lot of efficient algorithms to solve the pipe arrangement problems. One is a multi-objective genetic algorithm (MOGA) in which the gene represents both the locations of the equipments and the arrangement of the pipes. And a new crossover operation which merges two different piping layouts is proposed. To provide a fairly good initial population for the MOGA, a new heuristics making use of self-organization techniques to arrange equipments is proposed. The efficiency of the approach is demonstrated through experiments.

2. PROBLEM FORMULATION

The following information must be given to the automatic piping system in advance:

- 1) [Design Space] The range of the space to be designed is given. It is a box-shaped.
- 2) [Geometric information about equipments] Valves, pumps, T-branches, and external connection points of the design objective space are defined as equipments. The equipments are expressed by the size of boxes, and the relative location, orientation, and the diameter of the pipes connecting the equipments are given. Possible mounting directions of the equipments are also given.
- 3) [Information about connection of equipments] It is nearly the piping and instruments diagram (PID), that is, the information about whether or how the pipe connections of the equipments are connected to each other. In this paper, all the piping branches are defined as equipments, therefore the destination of a pipe connected to one connector of an equipment is only one.
- 4) [Geometric information about obstacles] Structural components and excluded equipments are considered to be obstacles. The locations and sizes of the obstacles are represented as a set of boxes and triangles.
- 5) [Aisle region] A region used as a passage for the crew is represented by a set of box. In this region the equipments are not placed. Placement of pipes in this area should be avoided as much as possible.
- 6) [Element placement candidate mesh points] Elements (that is, equipments and elbows of pipes) placement candidates are limited to mesh points.

Based on the information above, the automatic piping arrangement system explores the following design parameters:

- 1) [Locations and directions of equipments] Locations of the predetermined equipments are selected from

the mesh points by the system. Variations of the direction parameter are at most twelve. When mounting direction of the target equipment is constrained, the number of the direction variations would be less than twelve.

- 2) [Piping routes] Since piping branches are considered to be a variety of equipment, a pipeline simply connects two equipments. The start and end locations, directions, and diameter of the pipeline are given from the connected equipment's information. The pipeline's route is expressed by a list of coordinates of elbows. Accordingly, the parameters for routes of pipelines are subordinate to the parameters of connected equipments.

In this paper, all pipes are drawn parallel to the axis direction of the rectangular design space.

The design parameters are optimized by multi-objective algorithms specified in the following section 3.3. The objective of the optimization here is piping cost, number of elbows and valve operability, but it can change arbitrary.

3. A NEW AUTOMATIC DESIGNING SYSTEM

3.1 CODING AND CROSSOVER OPERATION

3.1 (a) Gene Coding

A gene for GAs is composed of design parameters which express locations and directions of equipments and piping routes. Each element of the gene for equipments consists of a set of parameters which expresses a location and a direction of the corresponding equipment. The gene for pipelines is variable length since the piping routes are expressed by the position of the elbows, the number of which is variable.

3.1 (b) Crossover Operation

This operation generates a new gene of a child C from genes of parents A and B. The position and the direction of each equipment in the child C inherits from the corresponding equipment in the parents either A or B with probability 50%. The process above is repeated until two conditions are satisfied: One condition is that arranged equipments do not interfere each other. The other is that the child C inherits at least one or more equipments from the different parent. (That is, the child C must have equipments from both the parent A and B.) After the condition above is satisfied, piping routes connecting equipments are generated as the following:

In the child C, the pipelines of which both sides are connected to equipments from the parent A are inherited from the corresponding pipelines in the parent A as it is. Similarly, the pipelines of which both sides are connected to equipments from the parent B are inherited from the corresponding pipelines in the parent B. When one side of the equipment in a pipeline is coming from the parent A (here we term it A-side), and the other side is coming from B (we term it B-side), then the pipeline of the A-side is constructed by inheriting the

corresponding pipe in the parent A and thereafter the pipe is cut off at an arbitrary elbow. Similarly the pipeline of the B-side is also constructed by inheriting the corresponding pipe in the parent B and the pipe is cut off at an arbitrary elbow. Under this condition, this pipeline would be broken at the cut off points. Therefore a new pipe is drawn between the cut off points within three elbows. If the pipes are interfering with equipments, obstacles, or themselves, then cut-off points in the inherited pipes from the parents are changed and a new pipe is redrawn between the cut-off points. When multiple pipelines are interfering, the pipeline which has either the largest number of interference or the largest diameter is re-constructed first.

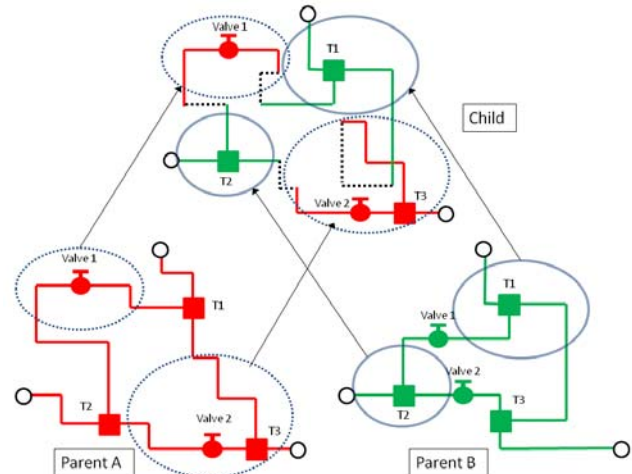

Figure 1: An example of the crossover operation

Figure 1 shows an example of the crossover operation. The pipes in the child C inherit the part of the parent A's pipes which are connected to the equipments coming from the parent A, and also inherit the part of the parent B's pipes which are connected to the equipments from the parent B. The broken parts of the pipelines in the child C is redrawn as shown by the dotted lines in the Figure 1. To avoid falling into an infinite loop of the crossover operation, the repetition of arranging equipments is limited at most 500 times, and the repetition of redrawing pipelines is limited at most 100 times. If the process breaks the limitations, the crossover operation results failure, then another pair of parents should be selected.

3.1 (c) Mutation Operation

In this operation, one equipment is randomly selected as a target, and the position and the direction of the target equipment is changed as shown in the following: In many cases, the random movement of the equipments results bad arrangement, therefore the target equipment is randomly moved to neighbour mesh points with 50% probability, or the target equipment is moved to the center of all the equipments which are connected to the target equipment. If the modification of the target equipment described above results interference of pipes or equipments, then the modification is undid and the operation is started over from selecting a target equipment.

3.2 GENERATING INITIAL POPULATION FOR GA

In our system, a genetic algorithm improves candidates of the arrangement design using the crossover operation and the mutation operation described in the previous section. Prior to that, an initial population which is composed of feasible arrangement design candidates must be provided in advance. Therefore, two types of heuristics are introduced to generate the initial population: One is Random Equipment Arrangement, the other is Self-organization Equipment Arrangement.

3.2 (a) Random Equipment Arrangement

Locations of all the equipments are randomly selected from the mesh points, and also the directions of all the equipments are randomly determined from the possible mounting directions. When there exist equipments which interfere with obstacles or the other equipments, the corresponding equipments are re-arranged randomly until the interference is dissolved. After all the equipments are arranged without interference, pipelines which connect the equipments are drawn using within three elbows. When the pipelines interfere with each other or the other objects, the system re-arranges equipments which are connected the most interfered pipeline, and all the pipelines are re-drawn within three elbows until the interference is dissolved. Figure 2 shows examples of the solution candidates generated by this operation.

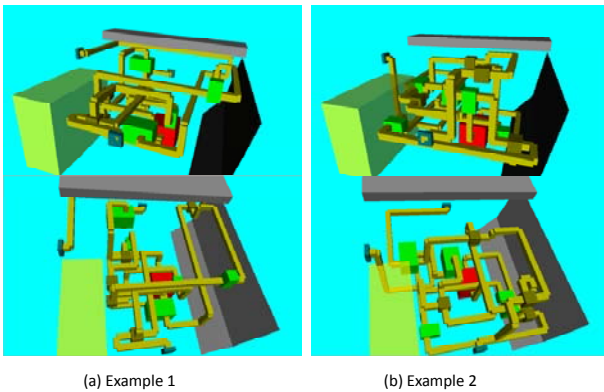

Figure 2: Randomly generated arrangements

3.2 (b) Self-Organization Equipment Arrangement

The random arrangement explained above tends to generate so inefficient candidates that the pipelines run throughout the space filling as shown in Figure 2. Here I propose a new algorithm which arranges the equipments to shorten the pipelines and also to avoid interference.

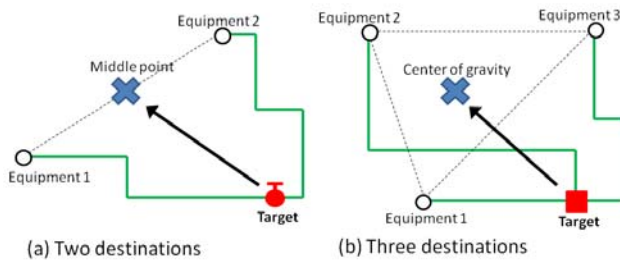

Figure 3: A basic concept of the self-organization

As shown in Figure 3, an equipment is selected as a target, and it is moved to the nearest possible mesh point of the center of all equipments which are connected to the target equipment. Actually, the destination point of the center location of connected equipments is weighted by the diameter of the corresponding pipes. Also the direction of the target equipment is changed so that the total length of the pipelines between the target and the other connected equipments becomes shortest. By applying a random selection of all the movable equipment for such scheme, lean and clean layout can be formed as a whole. However, this approach cannot cope with the following case: One is that there exists many obstacles in the design space, the other is to consider the valve operability. For this reason, this algorithm is used only to generate arrangements for the initial population.

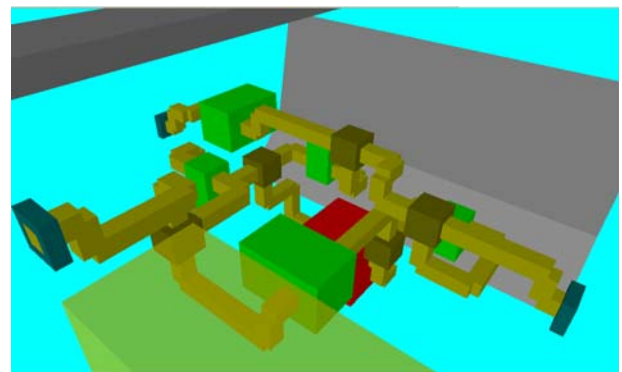

Figure 4: An example of the self-organization operation

Figure 4 shows an example obtained by this algorithm. Notice that wasteful pipeline drawing is obviously less than that of the random arrangements shown in Figure 2.

3.3 FORMULATION OF THE VALVE OPERABILITY

In this paper, the valve operability cost is given by the total energy consumed by the crew to move to all the valves from the aisle region going through accessible space. We define that a valve is "accessible" in the case of crew can move to a location where the valve can be operated by hand. I modify the recursive fill algorithm [8] to distinguish the accessible space with standing position from one with only squat (bending) position. Here explains the concept of the algorithm using a schematic 2-D sample shown in Figure 5. First, the design space is partitioned into regular grids, and free cells are distinguished from ones occupied by obstacles. We refer to the cells that include or interfere with obstacles (i.e., pipes, valves, or other equipments) as "obstacle segments", and the cells that are put in pathways as "aisle segments". We define "standing worker-segment matrix" as aggregated cells imitating shape of the standing crew (worker), and "squat worker-segment matrix" as aggregated cells imitating shape of the squatting crew. The cells that are swept by the squat worker-segment matrix without interfering with obstacle segments starting from an aisle segment are recognized as "accessible segments by squatting" (See pink segments in Figure 5 upper). Similarly, the cells that are

swept by the standing worker-segment matrix are recognized as "accessible segments by standing" (see blue segments in Figure 5 downward).

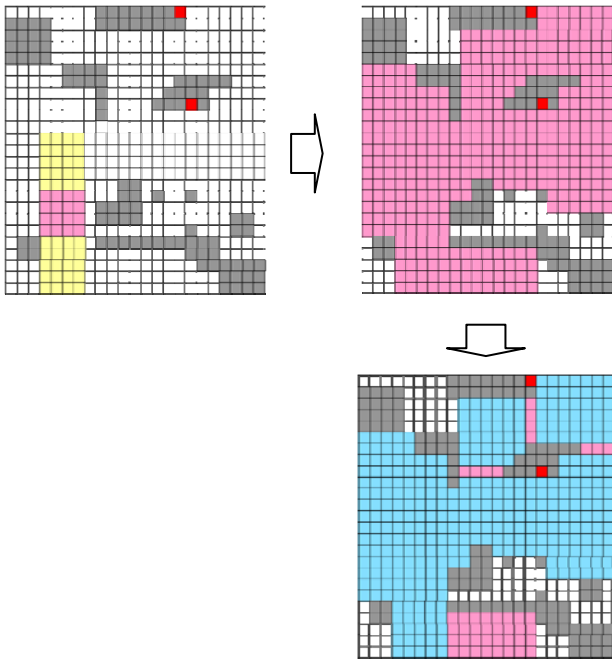

Figure 5: Recursive fill algorithm to find accessible space

After that, the energy to move to the valves is calculated in the following. First, the segments where the crew would operate the valves are identified. And a path-planning from each segment where the crew would operate the valve to any segments in the aisle region is executed through the accessible space found by the modified recursive fill algorithm. Dijkstra method is used for the path-planning. The consumed energy by the crew is estimated using RMR (relative metabolic rate). The movement energy with squatting is larger than the one with standing. For example, in Figure 6, right side path needs less energy than one of left side path, because the squatting section is smaller. These schemes described above are explained only in a 2-dimensional space, however, it is executed actually in 3-dimensional space. In the case that there exist valves which the crew cannot access, a large amount of cost is estimated as a penalty.

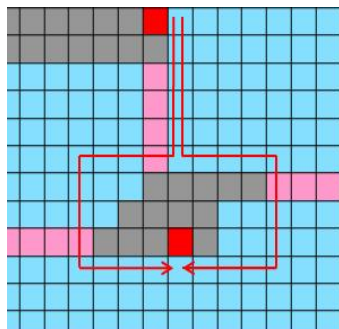

Figure 6: Two routes to a valve

4. EXPERIMENTS

4.1 SIMULATION SETTING

To confirm the effectiveness of the proposed method, it was applied to two types of pipe arrangement design problems: One has five valves, one pump, and five branches as shown in Figure 7, and the other has seven valves, one pump, and six branches as shown in Figure 8. The PID in Figure 7 is the same as shown in [8], but the size of the design space is that the width is 5 [m], the length is 5 [m] and the height is 2 [m] which is less than the height 5 [m] shown in [8]. Also it has the double size of the diameter of the pipeline through CP0, T-004, Valve-004 and CP1. That is, geometric constraint in this paper is tighter than [8]. The PID in Figure 8 is given by modifying the PID in Figure 7 adding two valves, one T-branch, and one external connection.

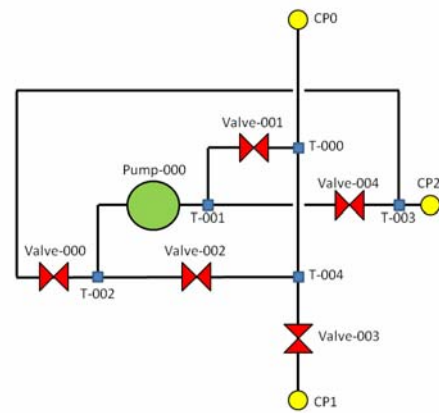

Figure 7: PID of 5 valves

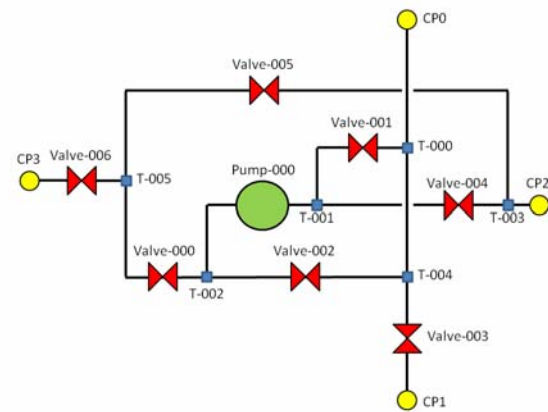

Figure 8: PID of 7 valves

It is three-objective optimization (minimization): The first is material cost, the second is the number of the elbows, and the third is the valve operability cost. The material cost is estimated by multiplying the length and the diameter of the pipes same as [8]. NSGA-II [9] is used as the multi-objective genetic algorithm that is the same as [8]. From preliminary experiments, the population size is set to 80 in the problem of five valves, and is set to 200 in the problem of seven valves.

4.2 RESULTS

All timings are reported on the Intel Core2 Quad 2.66GHz processor with 2GB RAM running Java ver.1.6 program codes on Microsoft Windows-XP. In the problem of five valves in the Figure 7, the calculation period for the evaluating solution candidates 18,880 times is about 10 days. Especially, the calculation time for generating the only initial population with 80 individuals takes 3.5 days of the 10 days. In the problem of seven valves in the Figure 8, the calculation period for the evaluating solution candidates 20,000 times is about 7 days, and the calculation time for generating the initial population with 200 individuals takes 2 days of the 7 days.

On the first stage of the optimization, the proposed system attempt to generate the initial population partly using Random Arrangement method. In the case that the equipments and pipelines are to be arranged into narrow design space, the Random Arrangement method can hardly find feasible solutions, therefore the calculation time to generate the initial population takes too much.

Figure 9 shows a pareto solution that consists of the smallest number (that is 13) of elbows at the 18,880th evaluations in the problem of five valves. The yellow transparent box is a pathway, the red box is a pump, and the dark gray objects are obstacles. All the pareto solutions got similar layout that arranges the equipments connected to fat pipes in a linear to shorten the fat pipes. However, migration paths expressed by dotted purple lines in the Figure 9 are often formed above pipes or valves, therefore the cost to place grating or the cost of the crew's position to operate valves must be considered in practice.

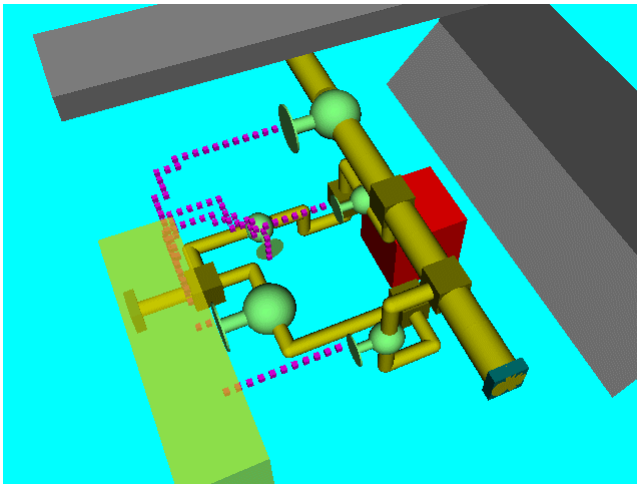

Figure 9: A solution in the problem of 5-valves

Figure 10 and 11 are typical pareto solutions at the 20,000th evaluations in the problem of seven valves. In the figures, dotted purple lines denote minimum-cost migration paths. In the solution shown in Figure 10, the material cost equals 2.7975, number of elbows is 24, and the valve operability cost is the best 270.8. In the solution shown in Figure 11, the material cost equals

2.6475, number of elbows is the best 22, and the valve operability cost is 286.0.

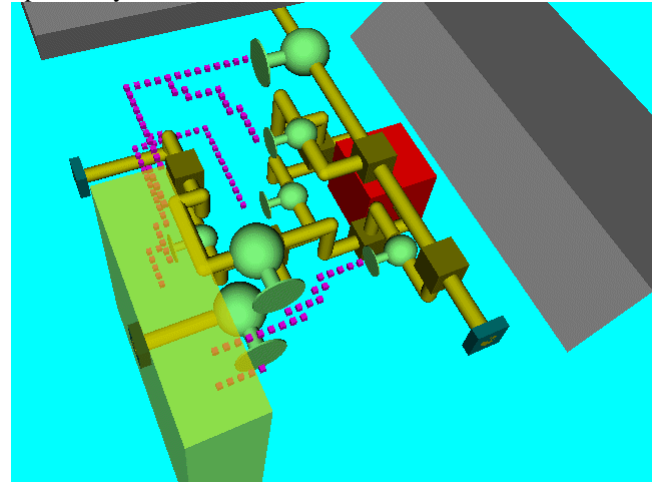

Figure 10: A solution in the problem of 7-valves

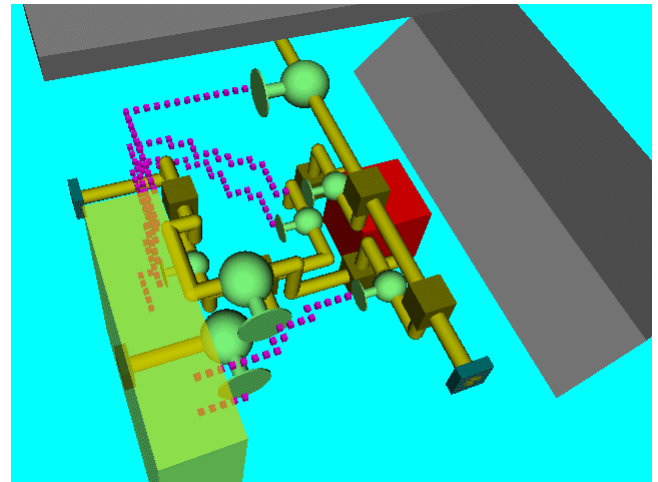

Figure 11: A solution in the problem of 7-valves

The valve operability of the solution in Figure 10 is superior to one of Figure 11, however, in the sense that the space secured widely like as in Figure 11 is preferred. It will need to consider in evaluation. Due to space limitations, the specific description is omitted, but the proposed method held a set of all the pareto solutions, so many useful solutions are generated.

Figure 12, 13, and 14 show the best solutions in the material cost, number of elbows, and the valve operability respectively along the optimization process of the problem of seven valves.

Since the optimization here is three objective.

It is difficult to illustrate distribution of the pareto solutions in 2-dimensional, however, Figure 15 shows the candidates of the solution at the initial generation, 1200th, 2400th, 4800th, 9600th, 15000th, and 20000th generations. The horizontal axis denotes the valve operability, and the vertical axis denotes the materials cost. The nearer candidates to the origin are the better. Figure 16 shows the number of pareto solutions along the process of the optimization.

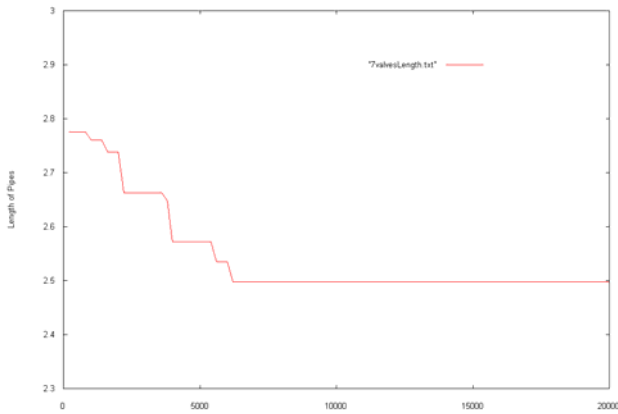

Figure 12: Best solution of material cost in GA population

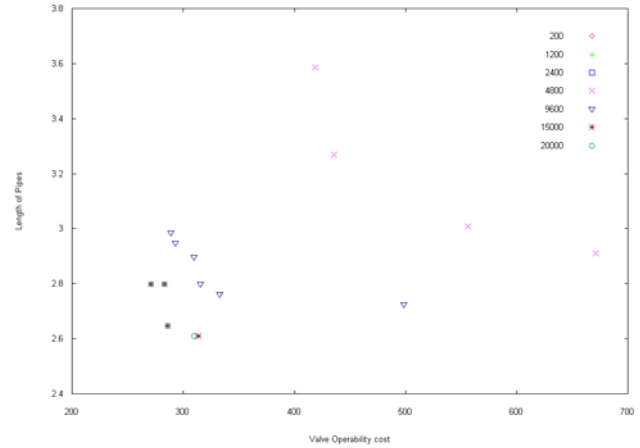

Figure 15: Pareto solutions at each search stage

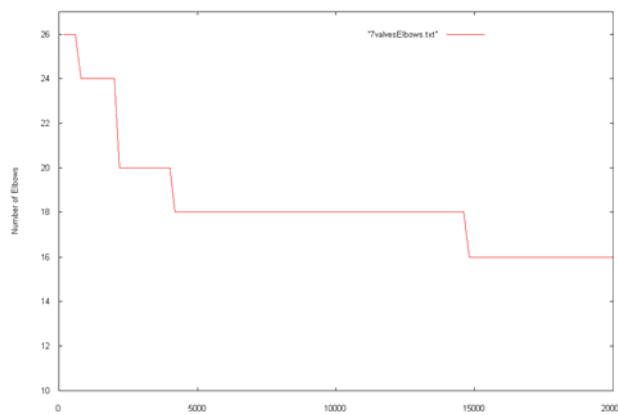

Figure 13: Best solution of number of elbows in GA population

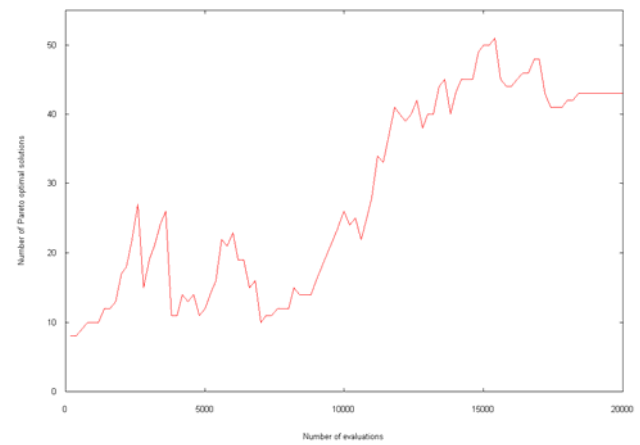

Figure 16: Number of Pareto solutions

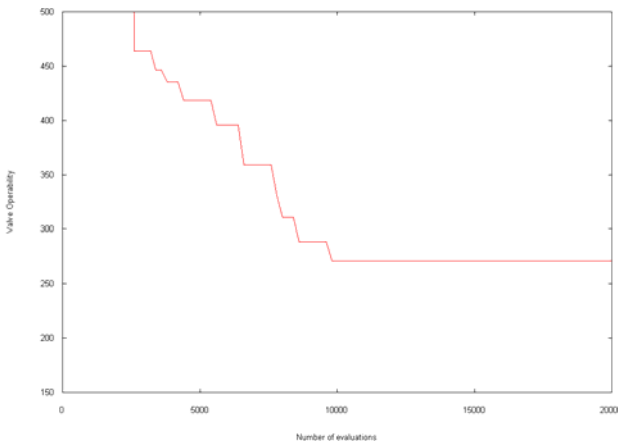

Figure 14: Best solution of valve operability in GA population

From Figure 12, 13, and 14, we notice that optimum solutions were found at the 15000th evaluations at each objective function, but from Figure 16, the system found new Pareto solutions after that. That is, since the NSGA-II method used in the proposed algorithm does not allow holding duplicate solution candidates, plural different solution candidates which have the same costs are generated.

5. DISCUSSION

5.1 SEARCH PERFORMANCE

Since experimental setting is rather different from previous works, a direct comparison is a stretch, but the quality of obtained solutions is dramatically improved. However, from Figure 9, 10 and 11, we notice that the solutions can improve by changing positions of some equipments or arrangements of pipes. The crossover operation and the mutation operation have room for improvement.

Also, the pipe drawing method used in the Random equipment arrangement method and Self-organized equipment arrangement method and the mutation operation is too primitive that draws a pipeline between corresponding two equipments simply within 3 elbows. For this reason, if too many obstacles are put in the design space, generating the initial population may be impossible in our system. Therefore, we are planning to make use of Dijkstra path planning method to generate pipelines between the equipments as a future work.

5.2 SHOWING PLURAL OPTIMUM SOLUTIONS

The multi-objective genetic algorithm used in our approach does not allow holding duplicate solutions in the population, however the cost can be the same. Therefore the plural different Pareto-optimum solutions

were shown as shown in Figure 10 and 11. In real piping arrangement design, the case would be exist that some design criteria are obscure, then the system which can show plural optimum solutions is practical.

5.3 LAYOUT CONSIDERING PIPING SUPPORTS

In our approach, geometrical information of the aisle region is given as a set of boxes in advance. Accordingly, the system avoids putting pipes in that region making use of the cost function. To introduce the similar mechanism, it is easy to draw pipes along walls or pipe-racks where piping supports are easily placed. However, notice that the user's load would increase to give the system geometrical information of the pipe-rack space as a set of boxes.

5.4 RULES EXPRESSED BY XML AND CONNECTION WITH CAD SOFTWARE

The proposed system makes use of XML (extensive markup language) files as the interface between the other systems. The connection with CAD software will be good since it is easy to convert the other file format. Also the system use file converter from plot-plan XML files to 3-D model X3D files. In real arrangement problems, possible mounting directions of the equipments are often constrained, so in the proposed system, the conditions of the mounting equipments are specified in the geometrical feature of the equipments which is expressed by XML. In the experiments, only the valves, pumps, T-branches, and connections to outsides are expressed as the equipments. However, any types of equipments such as concentric or eccentric reducers, crossing branches or strainers can be easily defined as similar equipments by using XML. How to express the general design guide for pipe arrangement or regulations by XML is a future work.

6. CONCLUSIONS

This paper presents a new automatic piping arrangement approach. First, the branches of pipes are considered to be a variety of equipment. Accordingly, the pipe routing problems are fairly simplified by removing the branches, and it derives many efficient algorithms to solve the pipe arrangement problems. One is a gene coding method for genetic algorithms in which the gene represents both the locations of the equipments and the arrangement of the pipes. And a new crossover operation which merges two different piping layouts is proposed. To provide a fairly good initial population for GA, a new heuristics making use of self-organization techniques to arrange equipments is proposed. The efficiency of the approach is demonstrated through experiments.

7. ACKNOWLEDGEMENTS

This work was supported by Japan Society for the Promotion of Science (JSPS) Grant-in-Aid for Scientific Research (B) 23360388.

8. REFERENCES

1. S. Sandurkar and W. Chen: 'GAPLUS-Genetic Algorithms Based pipe Routing Using Tessellated Objects', *Journal of Computers in Industry, Volume 38, Issue 3, pp.209-223*, April 1999.
2. H. Wang, C. Zhao, W. Yan and X. Feng: 'Three-Dimensional Multi-Pipe Route Optimization Based on Genetic Algorithms', *Knowledge Enterprise: Intelligent Strategies in Product Design, Manufacturing, and Management, Springer Boston, vol.207, pp.177-183*, 2006.
3. J. Park and R.L. Storch: 'Pipe-routing algorithm development: case study of a ship engine room design', *Expert Systems with Applications, Volume 23, Issue 3, pp. 299-309*, 1 October 2002,
4. T. Ito: 'A genetic algorithm approach to piping route path planning', *Journal of Intelligent Manufacturing, 10(1)*, 1999.
5. A. Asmara and U. Nienhuis: 'Automatic piping system in ship', *COMPIT - 5th Int. Conf. on Computer and IT Application Mar. Ind.* 2006.
6. A. Asmara and U. Nienhuis: 'Automatic Piping System Implementation: A Real Case', *COMPIT - 6th Int. Conf. on Computer and IT Application Mar. Ind.* 2007.
7. P.T. Martins and V.J.A.S. Lobo: 'A tool for automatic routing of auxiliary circuits in ships', *EPIA'09 - 14th Portuguese Conference on Artificial Intelligence, ALEA - Artificial Life and Evolutionary Algorithms, Aveiro Oct.* 2009.
8. H. Kimura and S. Ikehira: 'Automatic Design for Pipe Arrangement Considering Valve Operability', *Proceedings of the International Conference on Computer Applications in Shipbuilding 2009 (ICCAS 2009) Vol.2, pp.121--126, Shanghai, China, 1--3 Sep* 2009.
9. K. Deb, S. Agrawal, A. Pratab and T. Meyarivan : 'A fast elitist non-dominated sorting genetic algorithms for multiobjective optimization: NSGA II', *KanGAL report 200001, Indian Institute of Technology, Kanpur, India, 2000.*

9. AUTHORS' BIOGRAPHIES

Hajime Kimura holds the current position of Associate Professor at Department of Marine Systems Engineering, Kyushu University. His previous experience includes optimization in shipbuilding, etc.